

OPIsystems Three Piece Temperature Cable Support Installation Instructions

Description:

This bracket is designed to evenly distribute the loading of the temperature cable across four roof ribs. The temperature cable is secured and sealed against the roof sheet midway between two roof ribs. The load is transferred from the temperature cable through the threaded rods to the pipe, to the two angles, and then to the roof ribs. The bracket can be easily adjusted to give a uniform load. It is recommended for MDR2 cables from 35 to 50 feet in length.

Parts List:

| Part | Description | Qty |
|------|---|-----|
| 1 | Support Pipe 1.90" OD x 0.100" wall, 44" or 54" long | 1 |
| 2 | Support Angle 4" x 2.5" x 0.125" thick, 22" or 29" long | 2 |
| 3 | Pipe Hanger 1.5" trade size, galvanized | 2 |
| 4* | Temperature Cable with head, strain relief, bottom termination | 1 |
| 5* | Temperature Cable Angle base, Cast Aluminum (with cable) | 1 |
| 6 | Carriage head bolt 5/16-18 x 2", plated. Two sides flattened to 1/2" across | 2 |
| 7 | Lock Washer, 5/16", plated | 2 |
| 8 | Coupling nut, 5/16-18 x 1-1/8", plated | 2 |
| 9 | Nut, 5/16-18, plated | 2 |
| 10 | Threaded Rod, 5/16-18 x 8", plated | 2 |
| 11 | Hex Serrated Flange Locknut, 5/16-18, plated | 4 |
| 12 | Hex Washer Head Serrated Bolt, 1/4-20 x 1", plated | 8 |
| 13 | Hex Serrated Flange Locknut, 1/4-20, plated | 2 |
| 14** | Knurled threaded insert 1/4-20 x 0.027-0.165, yellow dichromate plated | 6 |
| 15* | Temperature Cable 2 wire connector (male) | 1 |
| 16 | Protective Rubber Cap, 1.25" diameter x 4" long | 1 |

* - Part of temperature cable. ** - Insertion tool required.

Tools required:

Drill with 1" (25mm) and 25/64" (10mm) drill bits
 2 @ 1/2" open ended wrenches
 7/16" wrench or socket
 **Threaded Insert Tool (pliers type or wrench type)
 Silicone Sealant

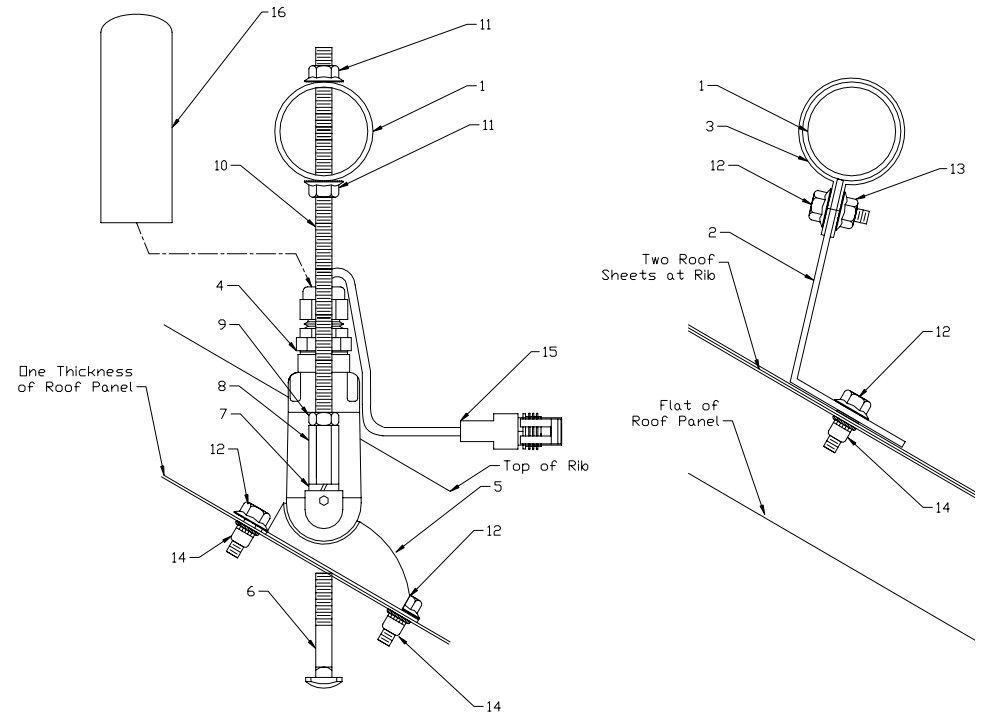

Side Views Of Cable, Pipe and Angle Mounts

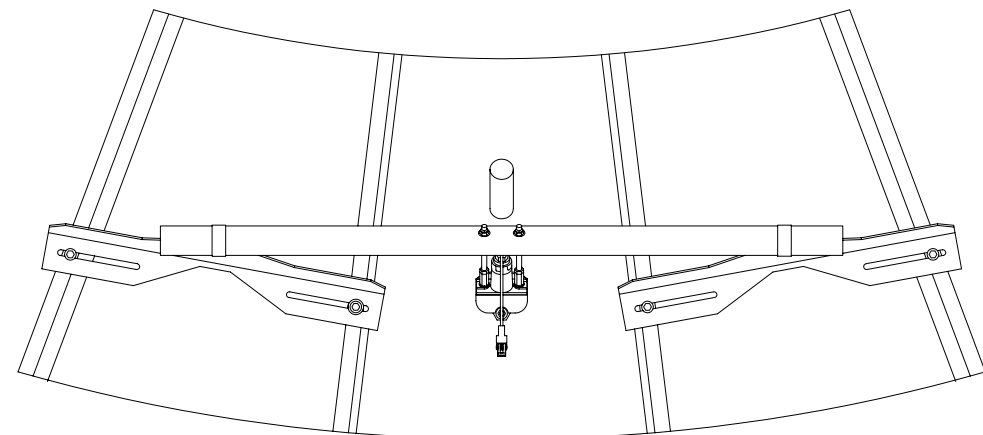

View of Assembled Supports Perpendicular to Roof

Installation Instructions

1. According to the chart below, drill a 1" (25mm) hole ½ way between two ribs on the flat of the roof sheet. This is the hole for the cable to drop through into the bin.

| | | | | | | | | | |
|--|------|-----|-----|-----|------|------|------|-----|-----|
| Bin Diameter (ft) | 24 | 27 | 30 | 32 | 33 | 36 | 38 | 42 | 48 |
| Center Cable? | No | No | No | No | No | No | No | Yes | Yes |
| Horizontal Distance out from Center (ft) | 7 | 7 | 8 | 8 | 8 | 9 | 9 | 12 | 14 |
| Running distance up from Eave (ft-in) | 5-10 | 7-7 | 8-2 | 9-4 | 9-11 | 10-5 | 11-8 | 8-2 | 9-4 |

| | | | | | | | | | |
|---|-----|-----|-----|-----|------|------|------|------|------|
| Bin Diameter (m) | 7.3 | 8.2 | 9.2 | 9.8 | 10.0 | 11.0 | 11.9 | 12.8 | 14.6 |
| Center Cable? | No | No | No | No | No | No | No | Yes | Yes |
| Horizontal Distance out from Center (m) | 2.1 | 2.1 | 2.4 | 2.4 | 2.4 | 2.7 | 2.7 | 3.6 | 4.3 |
| Running distance up from Eave (m) | 1.8 | 2.3 | 2.5 | 2.8 | 3.0 | 3.2 | 3.6 | 2.5 | 2.8 |

NOTE:

The short brackets {22" (0.56m) angles and 44" (1.12m) pipe} will be used for all bins without a center cable.

The long brackets {29" (0.74m) angles and 54" (1.37m) pipe} will be used for bins with a center cable.

2. Feed carriage bolts (6) into cable angle base (5) and head (4) from bottom up. Align flat sides of bolt head to slot to ensure bolt is bottomed out in the slot. Apply lock washer (7) and tighten coupling nut (8) with head angle base tipped to match the angle of the roof.
3. Place cable into hole in roof sheet being careful not to damage the cable on the sharp-edged hole. **IMPORTANT - adjust angle of the base so cable is vertical and tighten coupling nuts.**
4. Mark location of front and rear mounting holes for the angle pad. The rear location will either be a tab or a mounting hole. A washer head serrated bolt (12) will be used to hold down the tab or mounting hole. Pull cable out about 3 feet (1m) and lay cable head to the side. Drill 25/64" (10mm) holes at two marked locations.
5. Install threaded inserts (14) using the appropriate hand tool, making sure the insert is securely held in the roof sheet. Place a small amount of silicone sealant into each threaded insert.
6. Reposition the cable angle and head over the holes and attach to threaded inserts with washer head serrated bolts (12). Be sure rear bolt grips the mounting tab on angle base (if applicable). Tighten securely.
7. Thread a nut (9) 1" (25mm) then onto the threaded rod (10) and screw the threaded rod into the coupling nut (8) attached to the cable head (4). When the threaded rod bottoms out, tighten the nut against the coupling nut to lock the threaded rod in place. Repeat for both threaded rods.
8. Position serrated flange locknuts (11) with serrations up, 3 inches (75mm) down from top end of each threaded rod (10). Set the support pipe (1) on threaded rods. Place serrated flange locknuts (11) with serrations down to hold pipe loosely in place.
9. Loosely attach a pipe hanger (3) to each of the support angles (2). Slide an angle bracket and pipe hanger onto support pipe from each end of pipe until both angles are centered over two roof ribs. Be sure the angle mounting slots are facing down the roof sheet so the vertical load of the pipe will be centered over the slots.
10. With the angle centered across the ribs and square to the ribs, mark locations for two threaded inserts in the top of the roof rib in each of the angle's slots. Drill 25/64" (10 mm) holes and install threaded inserts (14) into the holes. Place a small amount of silicone sealant into each threaded insert. Repeat for the other support angle (2). **NOTE: You will need to rotate the angle (2) somewhat away from the centerline of the support pipe (1) to get it square with the roof sheet. This will slightly twist the pipe hanger (3) mounting. This is normal.**
11. Attach the angles to the threaded inserts in the roof ribs with washer head serrated bolts (12). You may need to loosen the nuts on the threaded rods to make the angles fit flat against roof. Tighten the pipe hanger mounting bolts (4).
12. Adjust the nuts holding the pipe until load is equalized side to side. Tighten nuts onto the pipe to secure.
13. Position temperature cable 2 wire connector (15) so that the wire is flat against cable head and pointing down the roof sheet. Slide protective rubber cap (16) over the wire and temperature cable head as far as it will go. This will seal the head from water.

OPIsystems One Piece Temperature Cable Support Installation Instructions

Description:

This bracket is designed to evenly distribute the loading of the temperature cable across two roof ribs. The temperature cable is secured and sealed against the roof sheet midway between two roof ribs. The load is transferred from the temperature cable through the angle to the roof ribs. The bracket can be easily adjusted to give a uniform load. It is recommended for MDR2 cables up to 35 feet (10.7m) in length and roof rib heights from 1.0" to 3.0" (25mm to 75mm).

Parts List:

| Part | Description | Qty |
|------|---|-----|
| 1 | Support Angle 2" x 2.5" (approx.) x 12 Ga., 28" long | 1 |
| 2* | Temperature Cable with head, strain relief, bottom termination | 1 |
| 3* | Temperature Cable Angle base, Cast Aluminum (with cable) | 1 |
| 4 | Carriage head bolt 5/16-18 x 4.5", plated. Two sides flattened to 1/2" across | 2 |
| 5 | Hex Serrated Flange Locknut, 5/16-18, plated | 6 |
| 6 | Hex Washer Head Serrated Bolt, 1/4-20 x 1", plated | 4 |
| 7** | Knurled threaded insert 1/4-20 x 0.027-0.165, yellow dichromate plated | 4 |
| 8* | Temperature Cable 2 wire connector (male) | 1 |
| 9 | Protective Rubber Cap, 1.25" diameter x 4" long | 1 |

* - Part of temperature cable. ** - Insertion tool required.

Tools required:

Drill with 1" (25mm) and 25/64" (10mm) drill bits
 1/2" wrench or socket
 7/16" wrench or socket
 **Threaded Insert Tool (pliers type or wrench type)
 Silicone Sealant

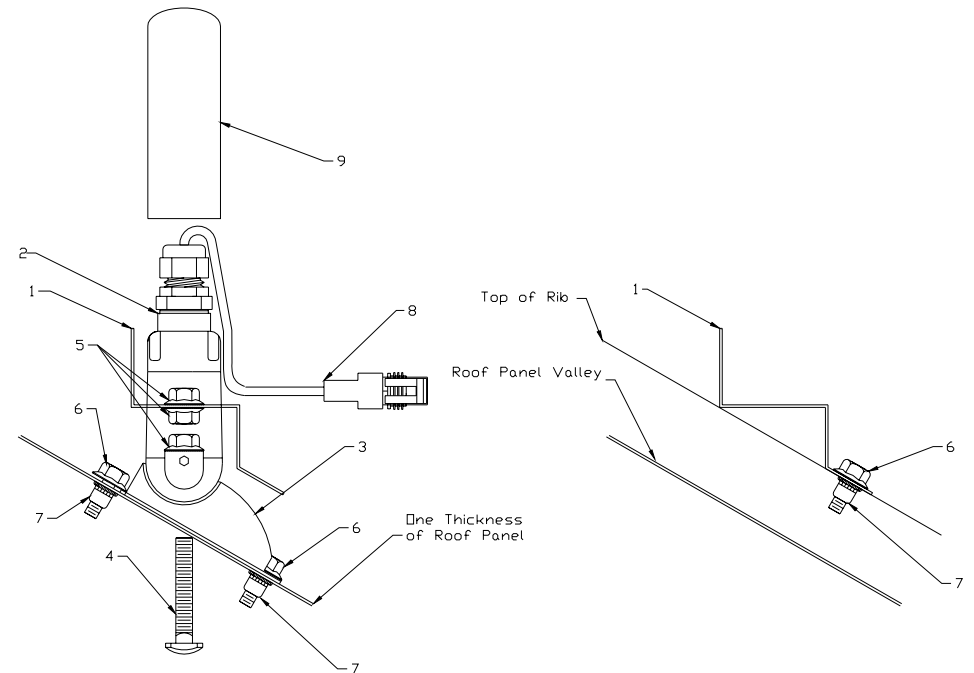

Side Views Of Cable and Angle Mounts

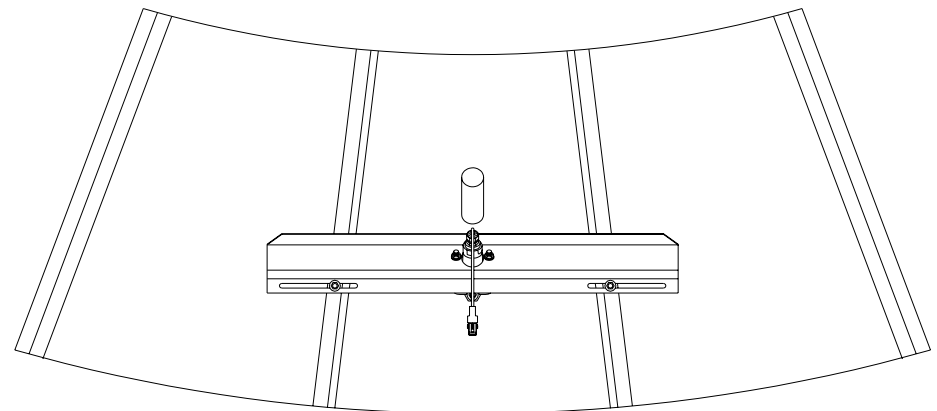

View of Assembled Supports Perpendicular to Roof

Installation Instructions

1. According to the chart below, drill a 1" (25mm) hole ½ way between two ribs on the flat of the roof sheet. This is the hole for the cable to drop through into the bin.

| | | | | | | | | | |
|--|------|-----|-----|-----|------|------|------|-----|-----|
| Bin Diameter (ft) | 24 | 27 | 30 | 32 | 33 | 36 | 38 | 42 | 48 |
| Center Cable? | No | No | No | No | No | No | No | Yes | Yes |
| Horizontal Distance out from Center (ft) | 7 | 7 | 8 | 8 | 8 | 9 | 9 | 12 | 14 |
| Running distance up from Eave (ft-in) | 5-10 | 7-7 | 8-2 | 9-4 | 9-11 | 10-5 | 11-8 | 8-2 | 9-4 |

| | | | | | | | | | |
|---|-----|-----|-----|-----|------|------|------|------|------|
| Bin Diameter (m) | 7.3 | 8.2 | 9.2 | 9.8 | 10.0 | 11.0 | 11.9 | 12.8 | 14.6 |
| Center Cable? | No | No | No | No | No | No | No | Yes | Yes |
| Horizontal Distance out from Center (m) | 2.1 | 2.1 | 2.4 | 2.4 | 2.4 | 2.7 | 2.7 | 3.6 | 4.3 |
| Running distance up from Eave (m) | 1.8 | 2.3 | 2.5 | 2.8 | 3.0 | 3.2 | 3.6 | 2.5 | 2.8 |

2. Feed carriage bolts (4) into cable angle base (3) and head (2) from bottom up. Align flat sides of bolt head to slot to ensure bolt is bottomed out in the slot. Apply serrated flange locknut (5) and tighten with head angle base tipped to match the angle of the roof.
3. Place a second set of serrated flange nuts (5) on the carriage bolts with serrations towards the threaded end of bolt. These will tighten to the bottom of the angle support (1) later.
4. Place cable into hole in roof sheet being careful not to damage the cable on the sharp-edged hole. **IMPORTANT - adjust angle of the base so cable is vertical and tighten nuts.**
5. Mark location of front and rear mounting holes for the angle pad. The rear location will either be a tab or a mounting hole. A washer head serrated bolt (6) will be used to hold down the tab or mounting hole. Pull cable out about 3 feet (1m) and lay cable head to the side. Drill 25/64" (10mm) holes at two marked locations.
6. Install threaded inserts (7) using the appropriate hand tool, making sure the insert is securely held in the roof sheet. Place a small amount of silicone sealant into each threaded insert.

7. Reposition the cable angle and head over the holes and attach to threaded inserts with washer head serrated bolts (6). Be sure rear bolt grips the mounting tab on angle base (if applicable). Tighten securely.
8. If protective cap (9) is installed on cable, remove it and feed the temperature cable 2 wire connector (8) through the large center hole of the angle support (1) from the bottom. Continue to slide the support angle (1) over the temperature cable head (2) and carriage bolts (4).
9. Apply serrated locknuts (5) onto carriage bolt threads (4) to hold angle in place. Adjust support angle so it is square to the roof sheet and mark the center of the roof ribs through the slots in the support angle (1).
10. Drill 25/64" (10 mm) holes and install threaded inserts (7) into the holes. Place a small amount of silicone sealant into each threaded insert.
11. Attach the angles to the threaded inserts in the roof ribs with washer head serrated bolts (6). Tighten the serrated flange nuts (5) near the temperature cable head (2) until the angle begins to take the load of the cable.
12. Position temperature cable 2 wire connector (8) so that the wire is flat against cable head and pointing down the roof sheet. Slide protective rubber cap (9) over the wire and temperature cable head as far as it will go. This will seal the head from water. It will not slide on all the way, depending on the roof rib height.